

# ASSEMBLY INSTRUCTION

PARTS :



(A) M6\*49mm BOLT  
8PCS



(B) M6\*34mm BOLT  
8PCS



(C) M6 WASHER  
8PCS



(D) SPRING WASHER  
8PCS



(E) PLASTIC CAPSULE  
8PCS



(F) PULL  
1PC



(G) M4\*19mm BOLT  
1PC



(H) M4 WASHER  
1PC

TOOL :



M4  
1PC



1PC

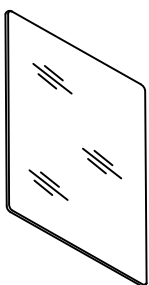
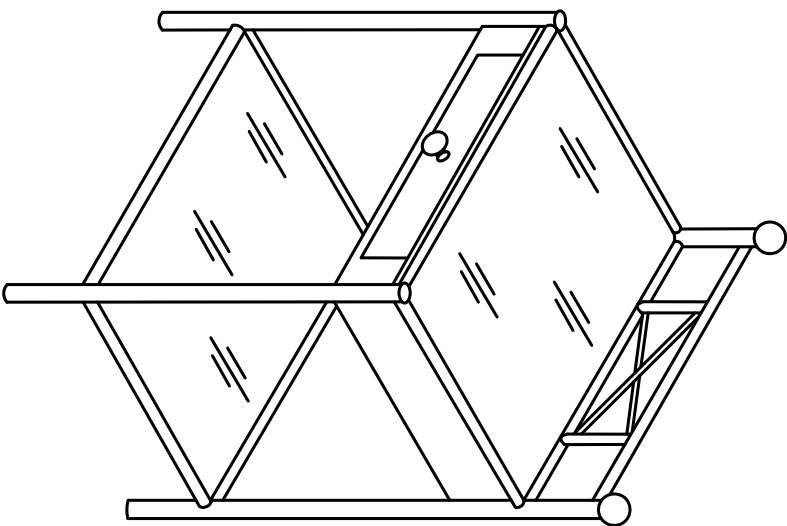

(I) TEMPERED GLASS 2PCS

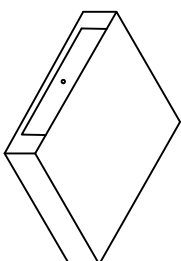

(J) IPC

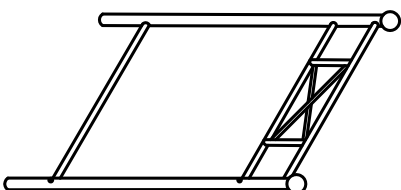

(K) IPC

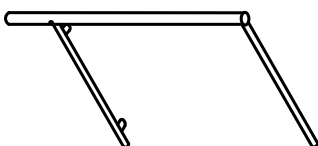

(L) 2PCS

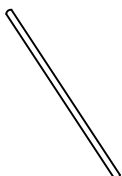

(M) 2PCS

IMPORTANT NOTE :

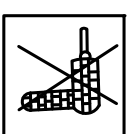

- \* THE PARTS OF F, G, H ALREADY INSTALLED INSIDE OF THE DRAWER.
- \* DO NOT FOR ANY REASON USE A POWER TOOL TO ASSEMBLE THIS PRODUCT.
- ITS USE WILL INVALIDATE ANY CLAIM YOU MAY HAVE AND COULD MAKE THIS PRODUCT UNSAFE.
- \* DO NOT TIGHTEN BOLTS COMPLETELY UNTIL ALL BOLTS ARE COMPLETELY LINED UP AND INSERTED INTO HOLES/NUTS,
- DO NOT OVER TIGHTEN SCREWS AND BOLTS TO AVOID STRIPPING.

STEP 1

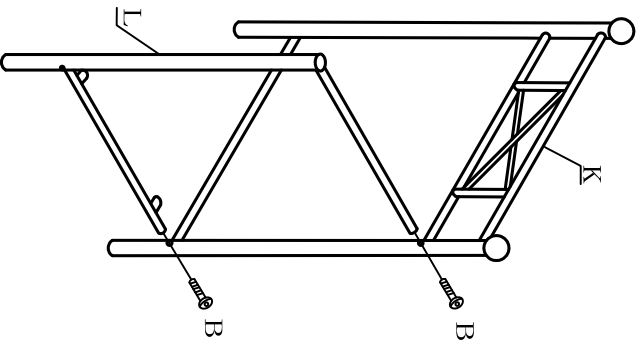

STEP 2

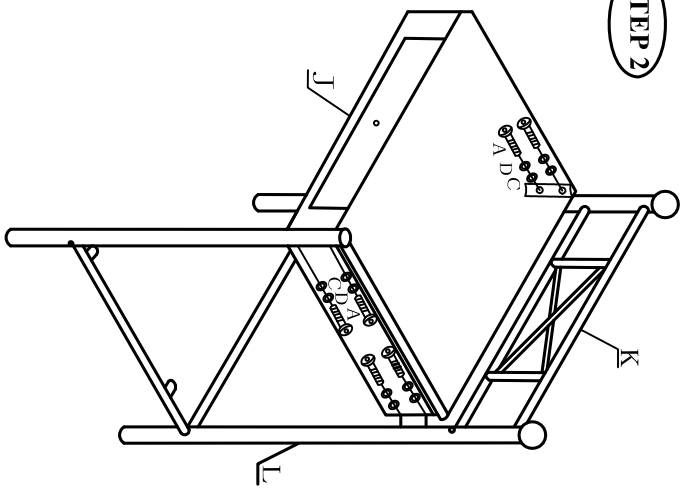

STEP 3

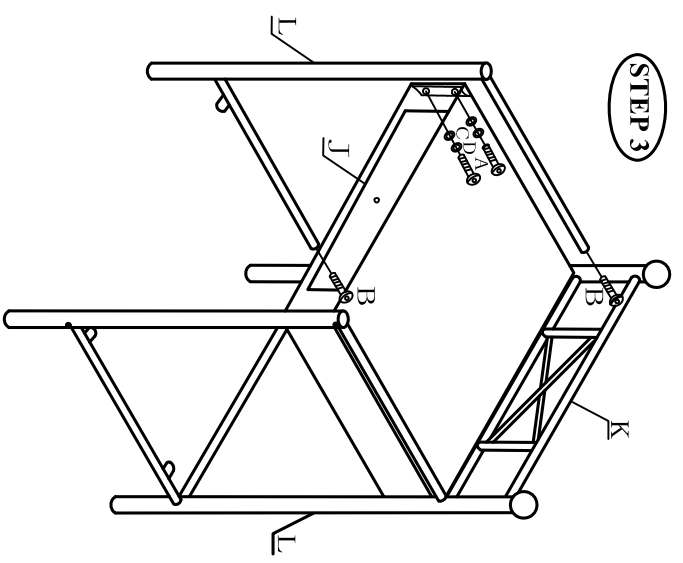

STEP 4

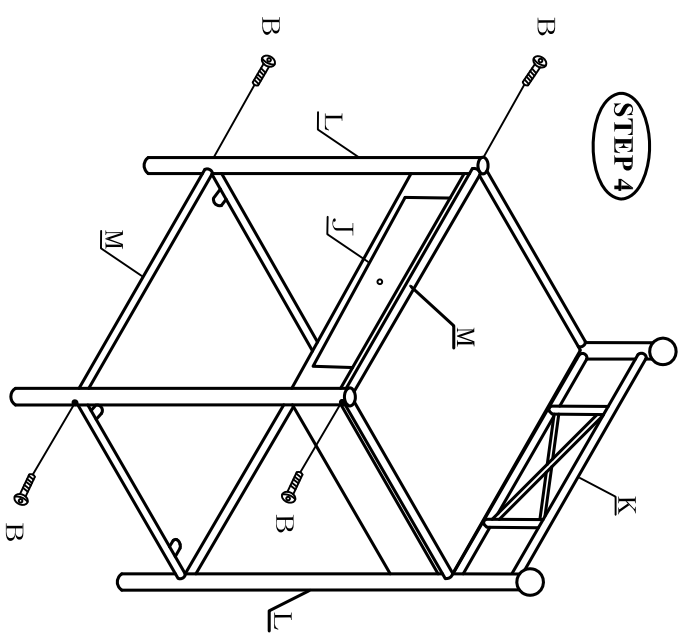

STEP 5

